

PRODUCT INTRODUCTION

Date: May 01, 2024

PRODUCT: Proclad Consort Panel System

07 42 13 Preformed Aluminium Panel – True pressure equalized rain screen.

Manufacturer:	Proclad Enterprises Ltd. 38 Rayborn Crescent St. Albert, Alberta T8N 4B1 Phone: (780) 458-5366	Contact: Doug Frank email: doug@proclad.ca
---------------	---	---

Product Description

The Proclad Consort Panel System is a modular panel system manufactured from monolithic (solid) aluminium. Panels are fabricated from coil coated 0.060” (1.53mm) aluminium. The panel system utilizes a vertical carrier track at vertical panel reveals (and mid-span as required) to achieve a true pressure equalized rain screen.

Key Product Standards:

- Manufactured from 0.060” (1.53mm) solid aluminium.
- Cannot burn or contribute to smoke emissions.
- Incorporates true pressure equalized rain screen performance – AAMA 508-07.
- High performance fluoropolymer coating applied in a continuous coil to coil process (minimum 20-year warranty)
- 100% recyclable using 5% of the energy.
- 96% recycled content when new.
- Not a petroleum-based product.

Proclad has been participating in the flat modular panel system market for over 30 years. We have worked hard to incorporate all the necessary features that are required for long-term performance of the complete wall assembly. We have achieved these levels through experience and the accumulation of trade knowledge since the early 1950’s.

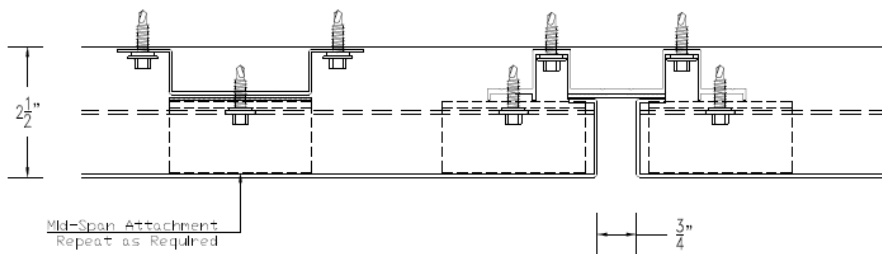
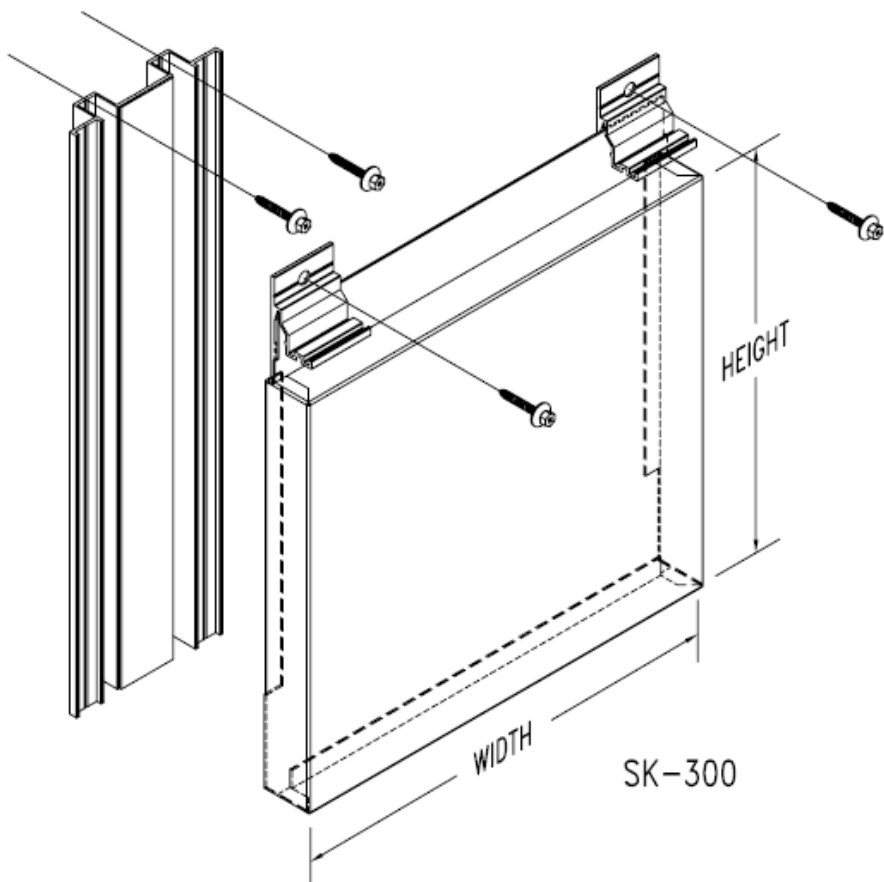

1 Vertical Panel Reveal
Section / PLAN

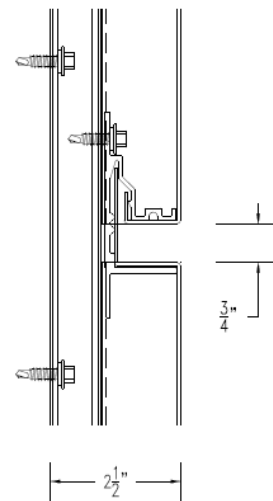

2 Horizontal Panel Reveal
Section / ELEVATION



Panel Sizes for Proclad Consort Panel System.
0.060" Aluminium vertical and horizontal panels.

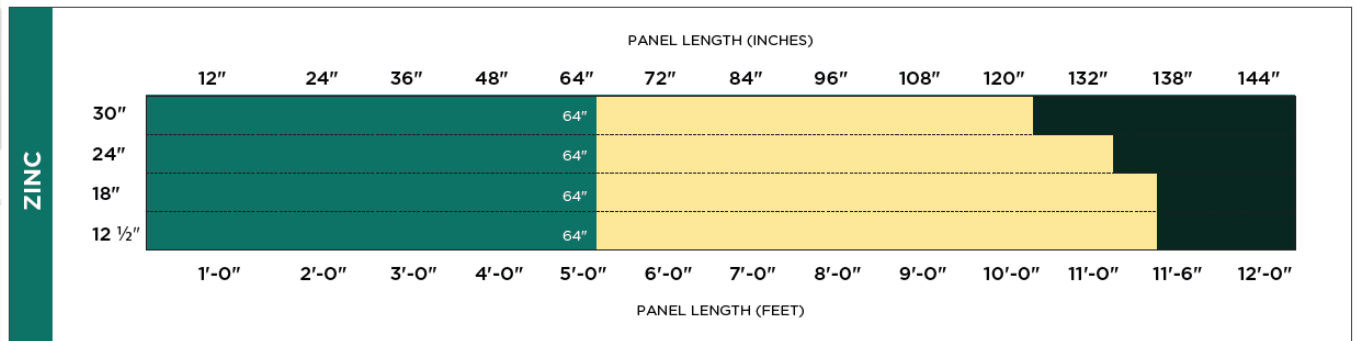
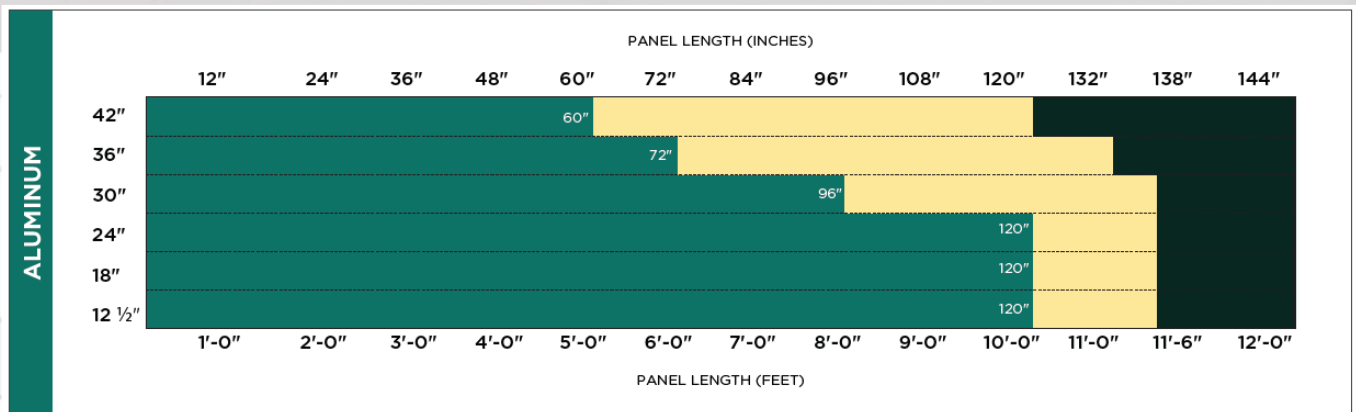

	Recommended Panel Sizes
	Large Panel Sizes
	Please Contact Proclad for guidance



Load Span table – Wind loads for Proclad Consort Panel System.
0.060” Aluminium vertical and horizontal panels.

16 Gage Supports At 16" On Center (1 fastener per support)			16 Gage Supports At 16" On Center (2 fasteners per support)		
Module (in.)	Allowable Load (psf)		Module (in.)	Allowable Load (psf)	
	Positive Load	Negative Load		Positive Load	Negative Load
12	>150.0	127.5	12	>150.0	132.2
18	>150.0	85.0	18	>150.0	132.2
24	>150.0	63.8	24	>150.0	102.4
30	85.6	51.0	30	85.6	102.0
36	49.6	42.5	36	49.6	72.4
42	31.2	36.4	42	31.2	45.6
48	20.9	30.5	48	20.9	30.5

Explanatory notes for Load/Span Table:

1. Capacities above include applicable safety factors as required by Code.
2. Panel module include the standard 3/4" reveal
3. Tables based on Allowable Stress Design (ASD)
4. All fasteners must be 1/4" diameter with 5/8" diameter combination washers or
5. Oil canning within standard guidelines as defined by MCA is not a cause for rejection
6. The calculated panel weight is 1.12 psf, based on a 24" wide x 36" long panel

Proclad Approved